

REVISIONS				
REV.	DESCRIPTION	CHK	APPD	DATE
A	RELEASE			2/12/11
B	A6: CLERICAL ERROR- .56 DIM WAS ON ANGLE (.41)			9/14/11

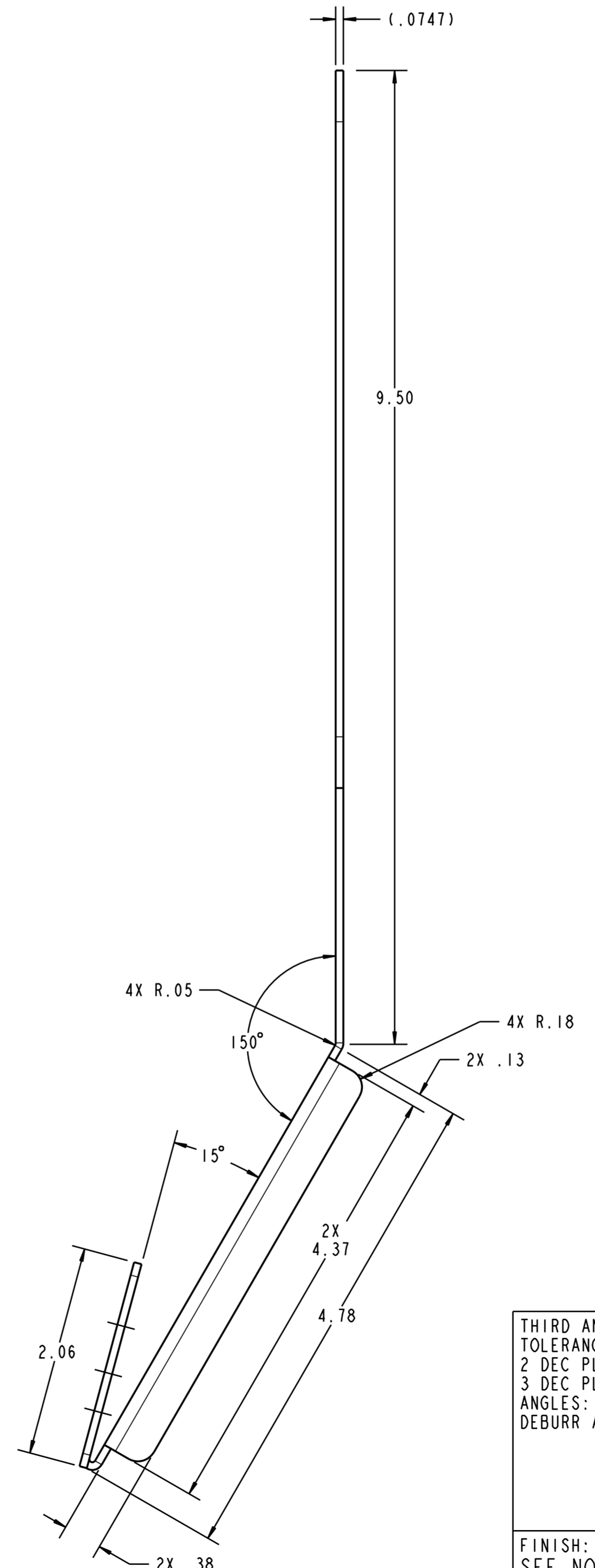
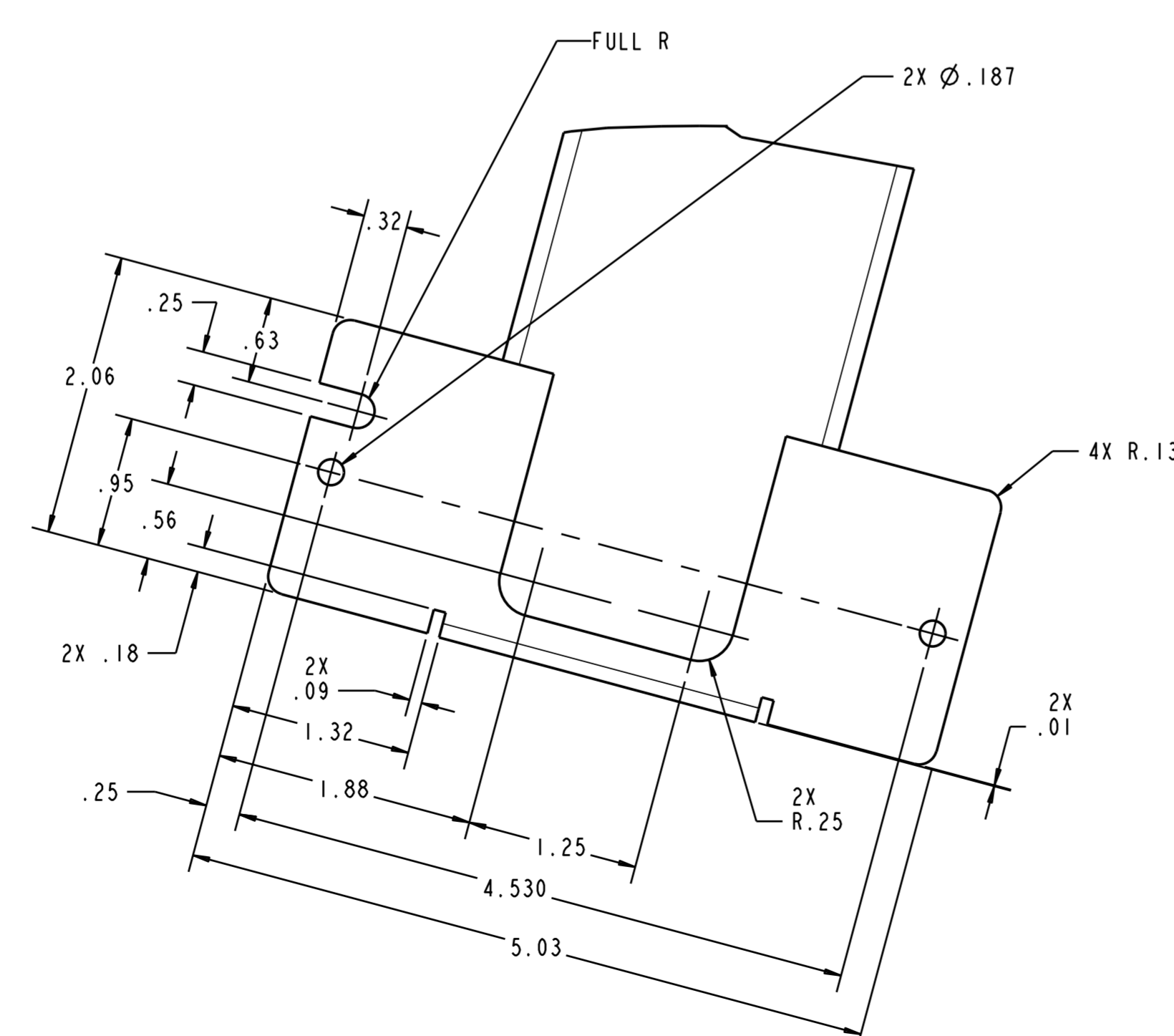
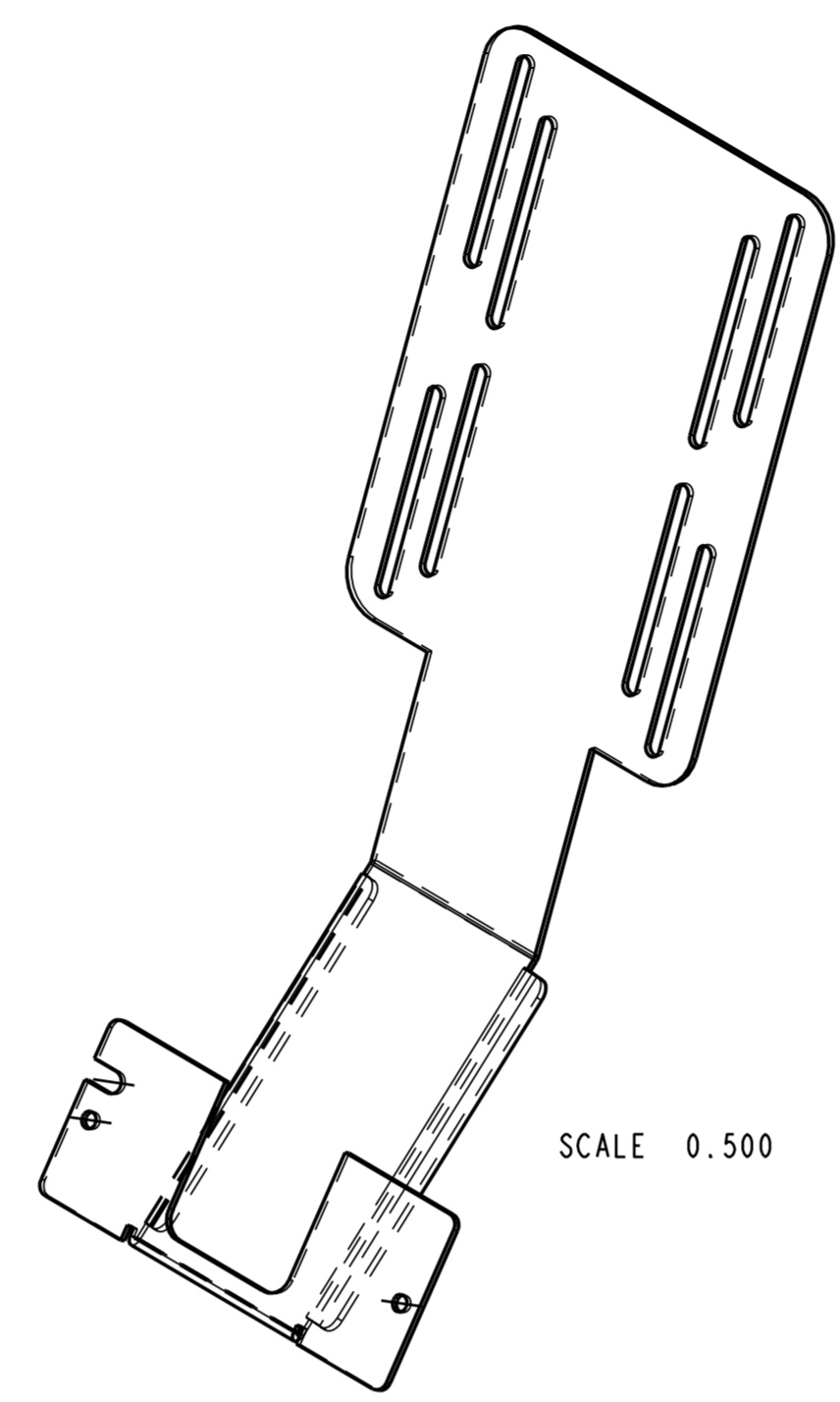
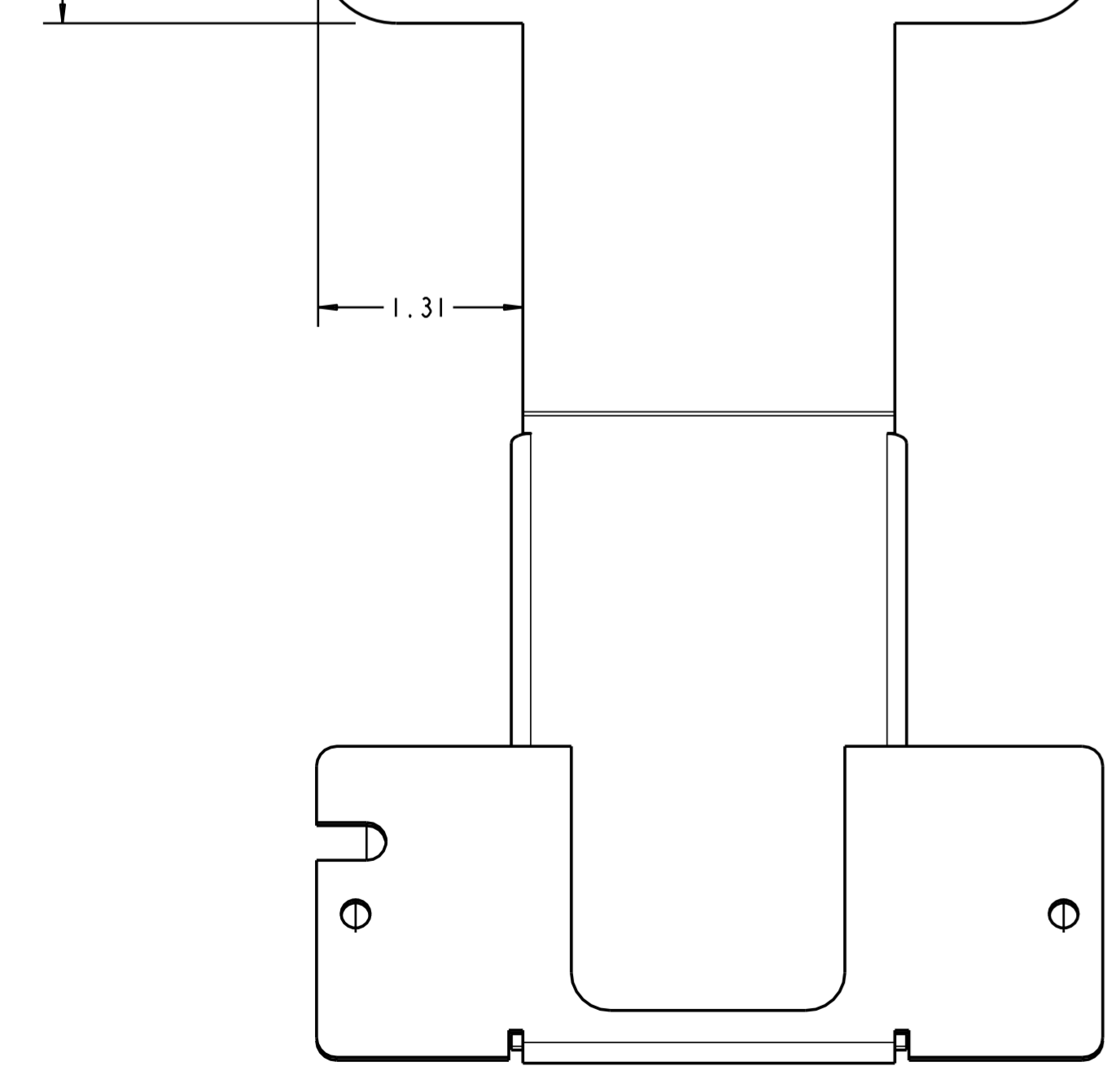
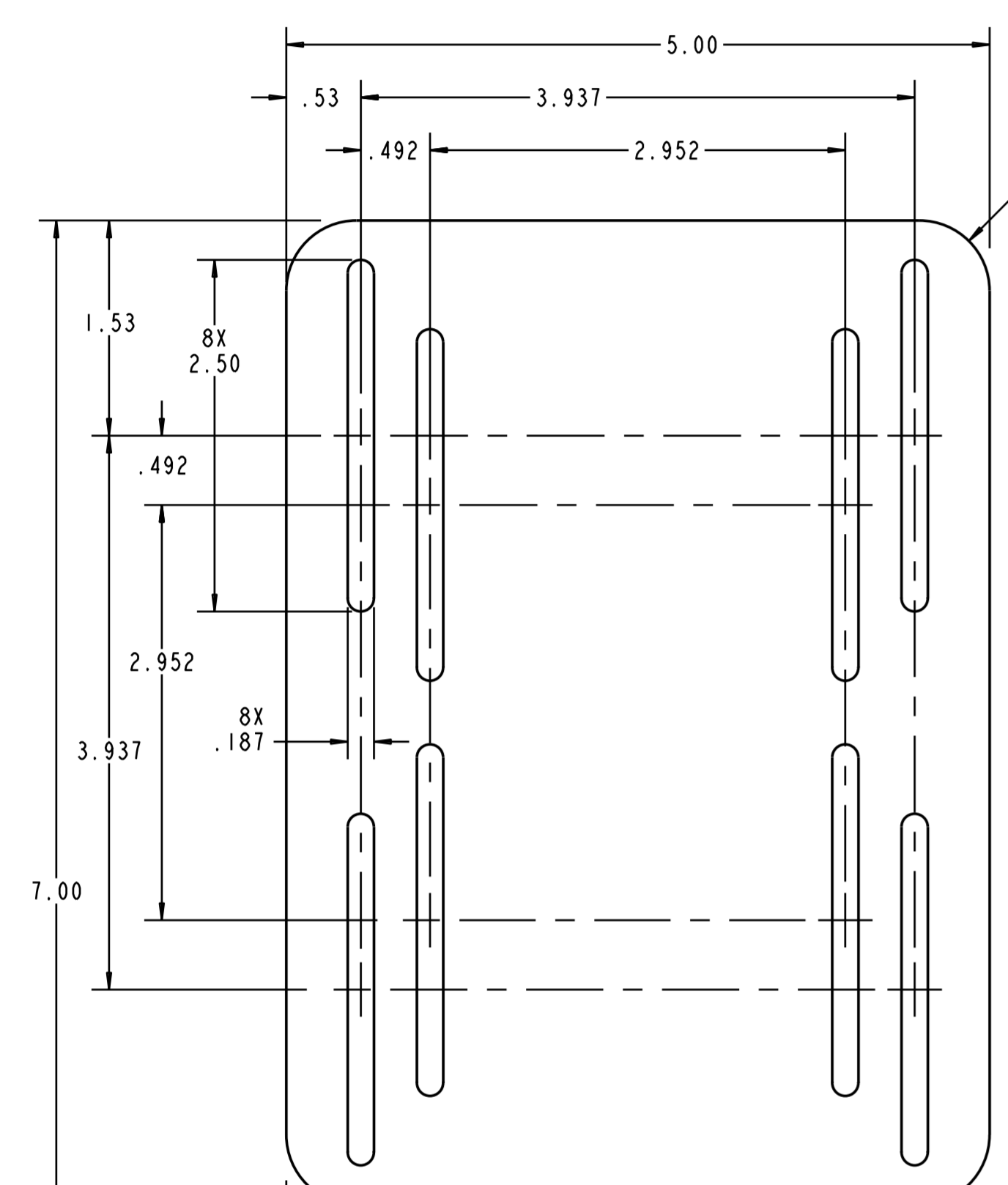
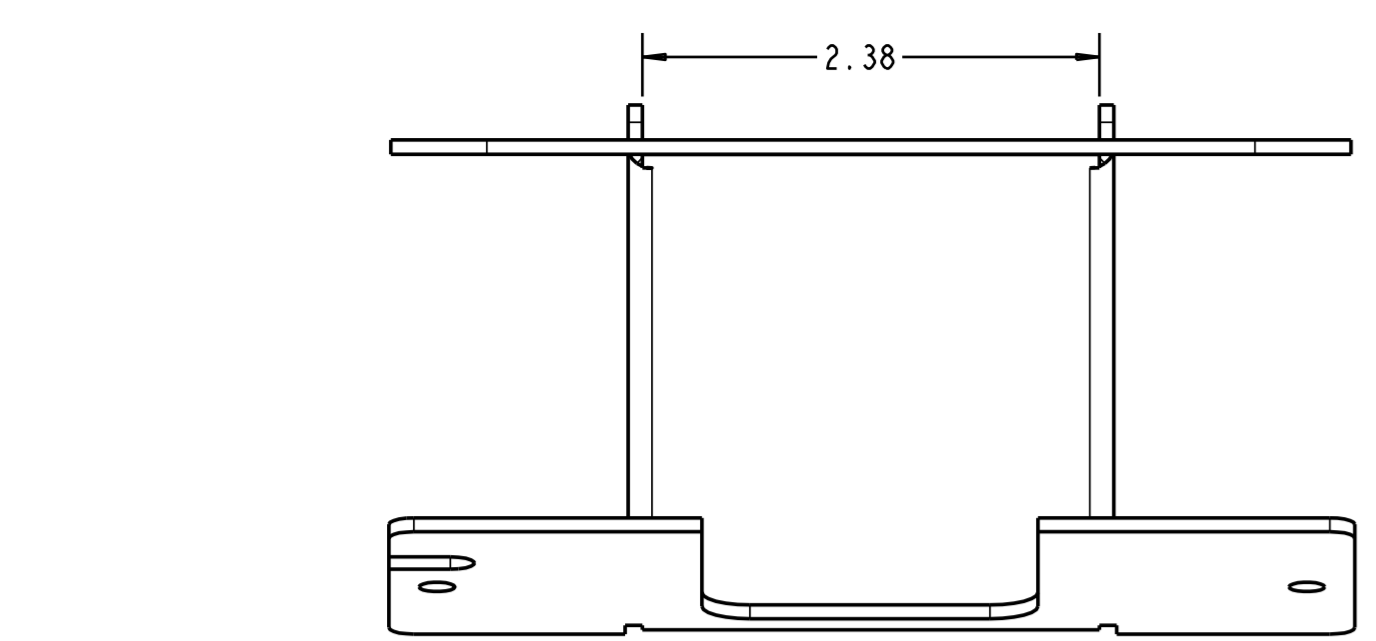

- NOTES: UNLESS OTHERWISE SPECIFIED
1. MATERIAL: 14 GAUGE (.0747" THK) CRS
 2. PRIME AND PAINT PER PURCHASE ORDER
 3. BEND RADII 90° ±1
 4. MINIMUM BEND RELIEFS REQUIRED
 5. BREAK SHARP EDGES .015R MAX

THIRD ANGLE PROJECTION TOLERANCES: 2 DEC PLCS: ±.015 3 DEC PLCS: ±.005 ANGLES: ±1° DEBURR ALL EDGES	PRODUCT LINE:		INSTRUMENTS & EQUIPMENT, CO.	
	DRAWN:	S.K.	2/12/11	TITLE: BRACKET, MSR/SCANNER PODIUM MOUNT
FINISH: SEE NOTE 2	APPROVED:	REV: B	41001075	
MATL: SEE NOTE 1	ISSUED:	D	SCALE: 1/1	SHEET 1 OF 1